

STRANDED COPPER CONDUCTOR ACCOMMODATED			BOLT SIZE	METRIC BOLT SIZE	COLOR CODE	DIE INFORMATION		MECHANICAL						HYDRAULIC						DIELESS (# CRIMPS)	WIRE STRIP LENGTH	REV	DATE	DESCRIPTION	ECO	BY	C'H'K
CODE (AWG)	NAVY	METRIC SIZE (CLASS 2)				DIE INDEX	TYPE	Y1MRTC	OUR840	MD6 MD7	MD6-R2 MD7-34R	PAT600 PATMD6	Y34A Y34B Y34BH	Y35, Y39 Y750, BAT35, PAT750	Y46 PAT46	Y45	Y48B	Y60BHU	A			10/10/2012	NEW SALES DRAWING CREATED	28954	HM	MA	
300 kcmil	300	150mm ² STR [16.2]	1/2	M12	WHITE	17 298	WHITE DIE SET	----	W30VT (4)	W30RT (4) W30VT (4)	W30RT (4) W30VT (4)	W30RT (4) W30VT (4)	A28AR (2)	U30RT (4) U28ART (4)	U30RT (4) U28ART (4)	U30RT (4) U28ART (4)	C30R (1) C28AR (1)	L30RT (1)	HYDRAULIC: Y644 (1) PAT644 (1) Y81KFT - SERIES (2) Y4PC834 - SERIES (2)	2 - 1/16"							
							NEST	----	----	----	----	----	B30D (2) A30D (2) Y34PR	U30D-1 (2) Y34PR	U30D-1 (2) Y34PR	U30D-1 (2) Y34PR	C30D (1) Y48PR	----									
							INDENTOR	----	----	----	----	----															

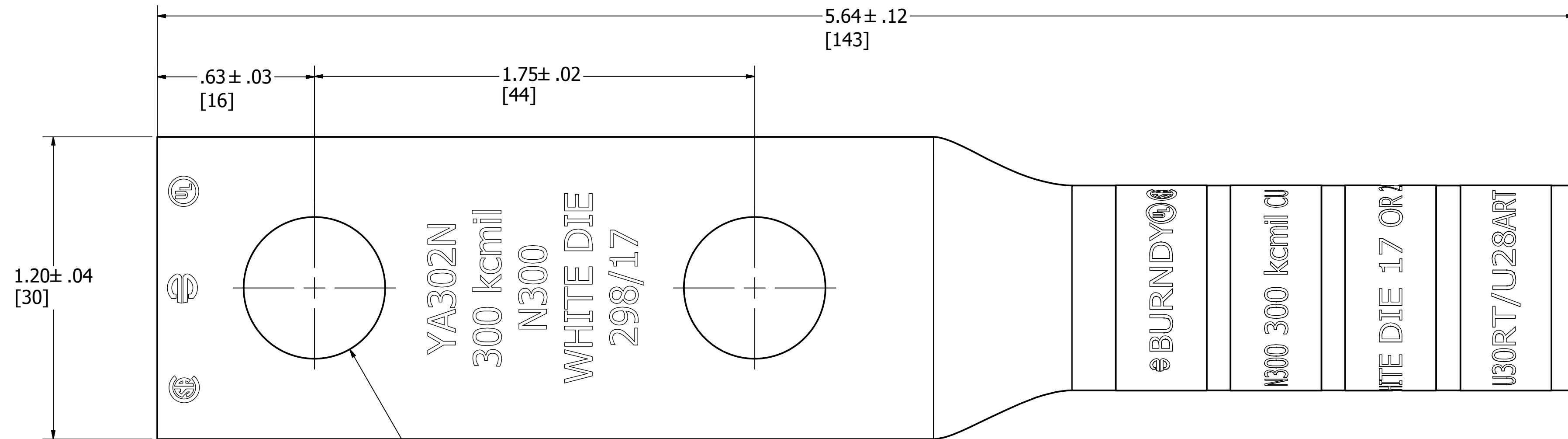

BARREL MARKING

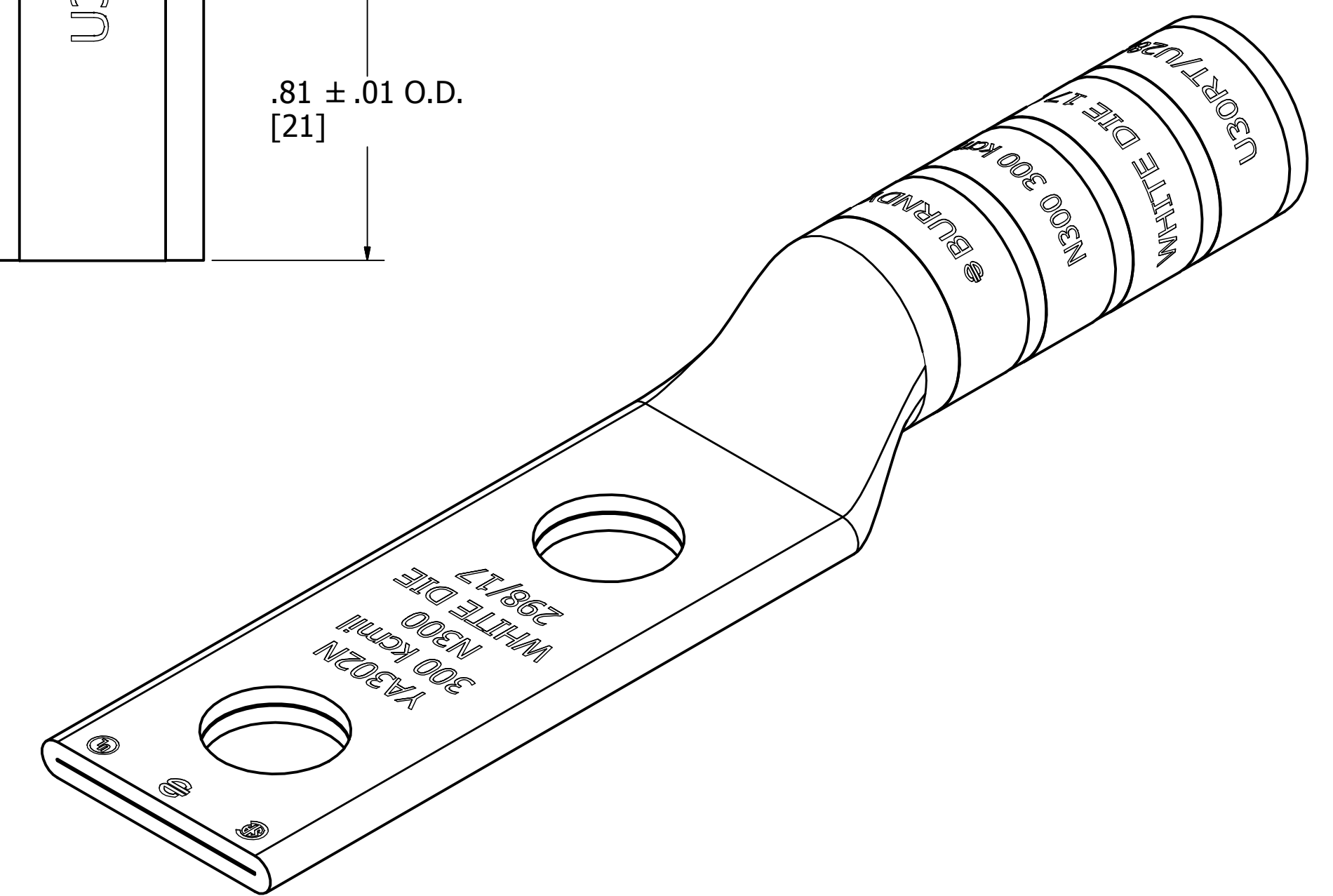
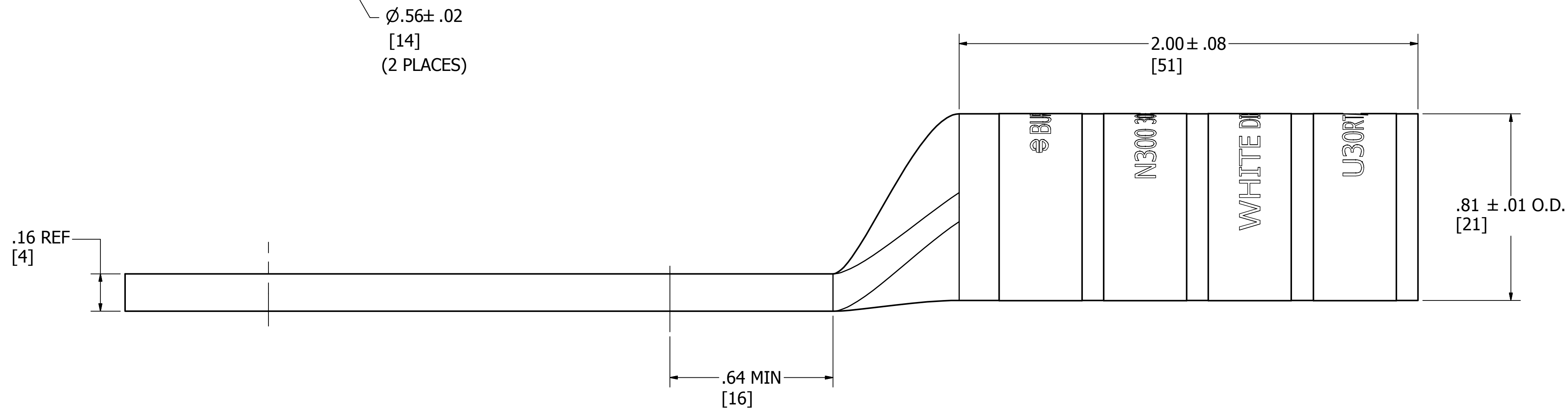

NOTES:

1. MATERIAL: COPPER TUBING
2. FINISH: TIN PLATED.
3. CATALOG # PT6515 ADAPTOR IS REQUIRED TO USE "U" DIES IN Y45 SERIES TOOLS.
4. CATALOG # PUADP-1 ADAPTOR IS REQUIRED TO USE "U" DIES IN Y46 SERIES TOOLS.
5. Y35P3 INDENTOR ADAPTOR REQUIRED FOR Y34PR INDENTOR.
6. PERMANENT DIE IN TOOLING.
7. DIMENSIONS IN BRACKETS [] ARE IN MILLIMETERS ROUNDED OFF TO THE NEAREST MILLIMETER, UNLESS OTHERWISE NOTED, AND ARE FOR REFERENCE ONLY.
8. FOR USE BY CUSTOMERS THAT HAVE THIS HYPRESS™ NO NEW Y34A HYPRESS™ TOOLS ARE BEING PROCESSED. Y34A USES A--D TYPE NEST DIES.
9. UL LISTED AND CSA CERTIFIED WIRE CONNECTORS.
10. "X", "W-RT", "W-VT", "U", & "L" DIE SETS ARE COLOR CODED. "A", "B", AND "C" DIES ARE NOT COLOR CODED. NESTS AND INDENTOR TYPE ARE NOT COLOR CODED.

HYLUG™			
ITEM NO: 502478			
CAT. NO: YA302N			
DRAWN BY: HMALHOTRA	10/10/2012		
CHECKER: J. MICHAUD	5/2/2013		
DSN APRVL: R. ROMAN	4/26/2013		
MFG APRVL: M. KNOPTON	3/18/2013		
QA APRVL: T. WATTS	3/8/2013		
MKT APRVL: J. SYLVIA	5/3/2013		
PROD FAM: CM&R COMPRESSION		DRAWING NO	REV
PROJECT #: --	SIZE	50010068	A
DOCUMENT TYPE: SALES	D	SHEET 1 OF 1	
REL LEVEL: WorkInProgress			